

# 2515382.1

---



Please read all instructions carefully before use and retain for future reference.



Protect your ears.



**CAUTION** Do not immerse in water.



Protect your hands.



Wear a dust mask.



Do not use in wet conditions.



Protect your eyes.



**CAUTION** Sharp edges.



Protective clothing must be worn



Please read all instructions carefully before use and retain for future reference.

**INTENDED USE** Only operate the power tool/machine for its intended purpose and within the parameters specified in this manual.

This power tool/machine is for domestic use only. This power tool/machine is not intended for use by persons with reduced physical, sensory or mental capabilities, or lack of experience and knowledge, unless supervised or given appropriate instruction concerning the product's use by a person responsible for their safety.

**GENERAL PRECAUTION** Do not allow to be used as a toy. Children should be supervised to ensure they do not play with the power tool/machine.

If the power tool/machine is not functioning properly, has been dropped, damaged, left outdoors, or immersed in liquid, do not use, contact DOMU Brands Customer Services.

Do not use the power tool/machine if any parts appear to be faulty, missing or damaged.

Ensure all parts are securely attached before use.

**RISK OF PERSONAL INJURY** Avoid body contact with earthed or grounded surfaces such as pipes, radiators, ranges and refrigerators. There is an increased risk of electric shock if your body is earthed or grounded.

Prevent unintentional starting. Ensure the switch is in the off position before connecting to the power source and/or battery pack, picking up or carrying the tool. Carrying power tools with your finger on the switch, or energising power tools that are switched on, invites accidents.

Do not operate power tools in explosive atmospheres such as in the presence of flammable liquids, gases or dust. Power tools create sparks which may ignite the dust or fumes.

Always wear eye protection. Any power tool can throw foreign objects into your eyes and cause permanent eye damage. Always wear safety goggles (not glasses) that comply with ANSI safety standard Z87.1. Every day glasses have only impact resistant lenses.

Do not expose power tools to rain or wet conditions. Water entering the power tools will increase the risk of electric shock.

Stay alert, watch what you are doing and use common sense when operating a power tool/machine. Do not use a power tool/machine while you are tired or under the influence of drugs, alcohol or medication. A moment of inattention while operating power tool/machine may result in serious personal injury.

Use personal protective equipment. Always wear eye protection. Protective equipment such as dust mask, non-skid safety shoes, hard hat, or hearing protection used for appropriate conditions will reduce personal injuries.

Prevent unintentional starting. Ensure the switch is in the off-position before connecting to power source and/or battery pack, picking up or carrying the tool.

Carrying power tool/machine with your finger on the switch or energizing power tool/machine that have the switch on invites accidents.

Remove any adjusting key or spanner before turning the power tool/machine on. A spanner or a key left attached to a rotating part of the power tool/machine may result in personal injury.

Do not overreach. Keep proper footing and balance at all times. This enables better control of the power tool/machine in unexpected situations.

Dress appropriately. Do not wear loose clothing or jewellery.

Keep your hair, clothing and gloves away from moving parts. Loose clothes, jewellery or long hair can be caught in moving parts.

If devices are provided for the connection of dust extraction and collection facilities, ensure these are connected and properly used. Use of dust collection can reduce dust-related hazards.

**WORK AREA SAFETY** Keep work area clean and well lit. Cluttered or dark areas invite accidents.

Do not operate power tool/machine in explosive atmospheres, such as in the presence of flammable liquids, gases or dust.

Power tool/machine create sparks which may ignite the dust or fumes.

Keep children and bystanders away while operating a power tool/machine. Distractions can cause you to lose control.

**GENERAL POWER TOOL USE AND CARE** Do not force the power tool/machine. Use the correct power tool/machine for your application. The correct power tool/machine will do the job better and safer at the rate for which it was designed.

Do not use the power tool/machine if the switch does not turn it on and off. Any power tool/machine that cannot be controlled with the switch is dangerous and must be repaired.

Disconnect the plug from the power source and/or the battery pack from the power tool/machine before making any adjustments, changing accessories, or storing power tool/machine tools. Such preventive safety measures reduce the risk of starting the power tool/machine accidentally.

Store idle power tool/machine out of the reach of children and do not allow persons unfamiliar with the power tool/machine or these instructions to operate the power tool/machine.

Power tool/machines are dangerous in the hands of untrained users.

Maintain power tool/machines. Check for misalignment or binding of moving parts, breakage of parts and any other condition that may affect the power tool/machines operation. If damaged, have the power tool/machines repaired before use. Many accidents are caused by poorly maintained power tool/machines.

Keep cutting tools sharp and clean.

Properly maintained cutting tools with sharp cutting edges are less likely to bind and are easier to control.

Use the power tool/machine accessories and tool bits in accordance with these instructions, take into account the working conditions and the work to be performed.

Use of the power tool/machine for operations different from those intended could result in a hazardous situation.

**CLEANING & MAINTENANCE** Never soak or immerse electrical components and or a component that has a plug attached.

Disconnect the plug from the power source before making any adjustments, changing accessories, or storing. Such preventive safety measures reduce the risk of starting the power tool accidentally.

Ensure the motor has fully stopped before cleaning, clearing a blockage, checking, or carrying out any maintenance on the tool.

Maintain your power tool. Check for misalignment or binding of moving parts, breakage of parts and any other condition that may affect the power tool's operation.

If damaged, have the power tool repaired by a qualified repair person before use. Many accidents are caused by poorly maintained power tools.

Keep cutting tools sharp and clean. Properly maintained cutting tools with sharp cutting edges are less likely to bind and are easier to control.

Regularly check external nuts and fixings to ensure vibration caused by normal use has not begun to loosen them. Store idle power tools out of reach of children and do

not allow persons unfamiliar with the power tool or these instructions to operate the Breaker.

Locate the power tool out of reach of children, in a dry, locked unit.

Make sure that the cord is located so that it will not be stepped on, tripped over, or otherwise subjected to damage or stress.

Remove the plug from the mains socket / battery (where applicable) before carrying out any adjustment or maintenance.

Always store the power tool/machine in a dry place.

If the power cord is damaged, it must be replaced by a qualified service technician.

Keep the ventilation slots and motor housing as free of dirt and dust as possible (where applicable).

Clean the power tool/machine by rubbing it with a clean cloth and blow it clean using low-pressure compressed air is recommended.

Ensure you have all the pieces listed. If you are missing any components, contact our customer services department at **support@domu.co.uk** DO NOT proceed with assembly if any components are missing.

## LAWNMOWERS

Do not expose the Lawnmower to rain or wet conditions. Water entering the Lawnmower will increase the risk of electric shock.

Always check the area to be worked on for wire and other debris that could cause potential damage to the Lawnmower and injury to the operator.

Always wear substantial footwear and long trousers whilst operating the Lawnmower.

Never operate the Lawnmower without the Grass Catcher in place, unless otherwise specified in this manual.

Keep children, pets and bystanders away whilst operating the Lawnmower. Distractions can cause you to lose control. Switch on the motor carefully according to instructions and with feet well away from the blade.

Do not start the Lawnmower whilst standing in front of the discharge opening. Keep clear of the discharge opening at all times. Do not use the Lawnmower if the switch does not turn it on and off. Any garden tool that cannot be controlled with the switch is dangerous and must be repaired. Do not tilt the Lawnmower when switching on the motor, except for if the machine has to be tilted for starting. In this case, do not tilt it more than absolutely necessary and lift only the part which is away from the operator. Always keep your arms and legs a safe distance from the cutting mechanism, particularly after turning the appliance on.

Do not put hands or feet near or under rotating parts.

Keep hair, loose clothing, fingers, and all parts of body away from openings and moving parts.

Walk, never run.

Do not overreach. Keep proper footing and balance at all times. Always be sure of your footing on slopes.

Always mow across the face of slopes, never up or down.

Do not mow excessively steep slopes.

Exercise extreme caution when changing direction on slopes. Use extreme caution when reversing or pulling the Lawnmower towards you.

Do not transport the Lawnmower whilst the power source is running. If the Lawnmower has to be tilted when transporting it between areas, stop the blade before attempting to move it. The same applies when crossing surfaces other than grass. If a foreign body or other debris accidentally become entangled in the Lawnmower, stop it immediately. Disconnect from the mains and do not use again until cleared.

If the Lawnmower makes any unusual sounds or starts to vibrate abnormally, stop it immediately. Disconnect from the mains and investigate the cause. Inspect for damage, tighten any loose parts and have any damaged parts repaired or replaced.

## TECHNICAL SPECIFICATION

Rated Voltage 230V - 240V

Rated Power 1600W

Rated Frequency 50Hz

## DECLARATION OF CONFORMITY

We

**DOMU Brands Ltd  
6th Floor The Tower  
Deva City Office Park  
Manchester  
M3 7BF**

**DOMU Brands Ltd  
Unit 30, Finlan Road  
Stakehill Industrial Estate  
Middleton, Manchester  
M24 2RW**

Declare under our sole responsibility the product:

SKU  
**2515382.1**

Description

**1600W Corded Lawn Mower**

Complies with the essential requirements of the following directives:

**2006/42/EC  
2000/14/EC  
2014/30/EU  
2011/65/EU**

And the Standards

**BS EN 60335-1:2012+A13:2017 , BS EN 60335-2-77:2010, BS EN 62233:2008, EN 55014-1:2006+A1+A2  
EN 55014-2:2015, EN 61000-3-2:2014, EN 61000-3-3:2013**

Authorised Signatory on behalf of DOMU Brands Ltd.

A handwritten signature in black ink, consisting of several loops and a long horizontal stroke at the end, positioned above a solid horizontal line.

## COMPONENTS

---

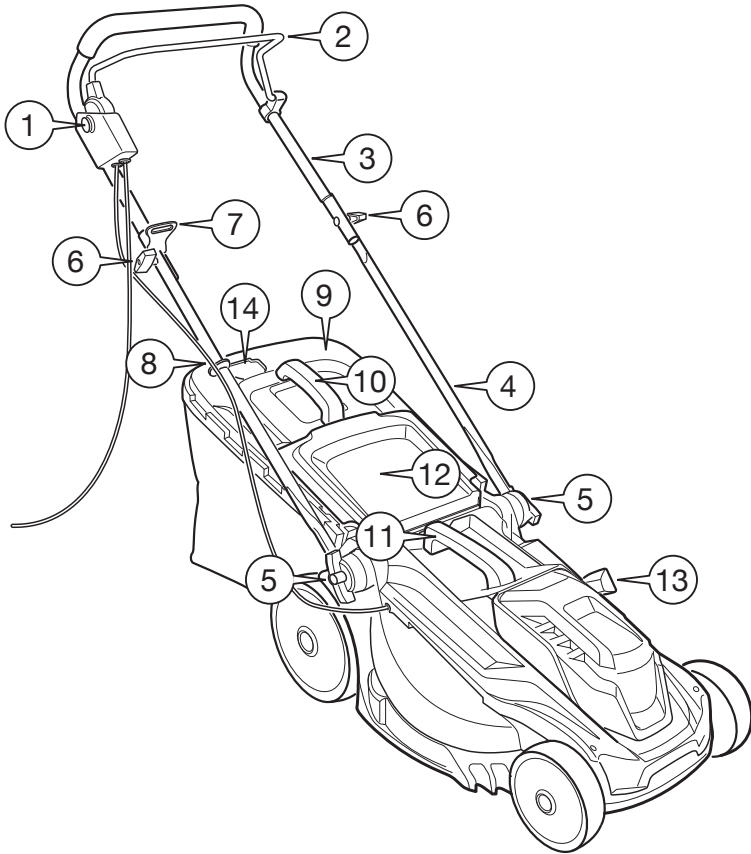

- 1. Safety Button
- 2. Switch Lever
- 3. Upper Support Bars
- 4. Lower Support Bars
- 5. Locking Knob Assembly 2x
- 6. Wing Nut 2x
- 7. Cable Relief

- 8. Wire Clip
- 9. Collection Basket Cover
- 10. Grass Collector Handle
- 11. Carry Handle
- 12. Rear Flap
- 13. Cutting Height Adjustment Lever
- 14. Grass Indicator

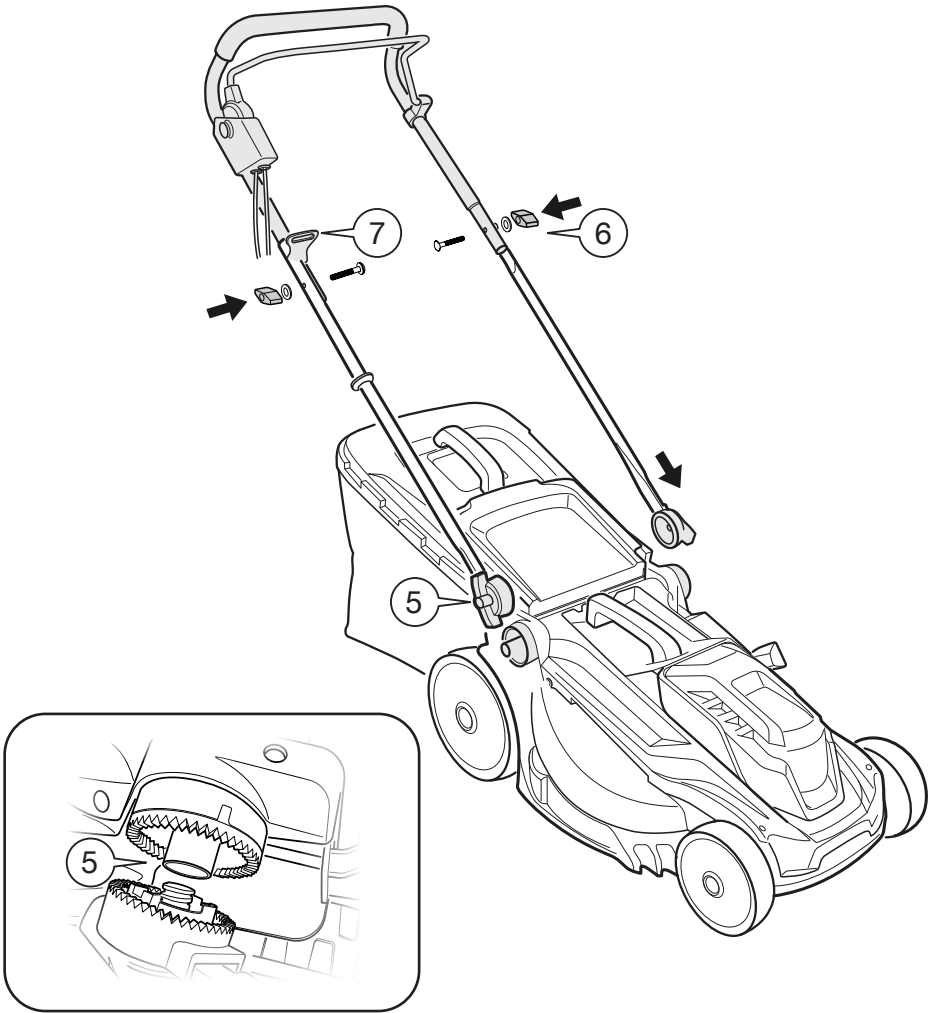

Connect the **LOWER SUPPORT BARS (4)** with the **UPPER SUPPORT BARS (3)** using the **WING NUTS (6)**  
The **LOWER SUPPORT BARS (4)** is fixed on the main unit through the engagement of the teeth on the **LOCKING KNOB ASSEMBLY (5)** Rotate to lock.

**NOTE** The **CABLE RELIEF (7)** should be added to the **UPPER SUPPORT BARS (3)** before assembling the support bars.

## ASSEMBLY

---

Click the **CARRY HANDLE (10)** into the top panel of the **COLLECTION BASKET COVER (9)**

Secure with screw provided.

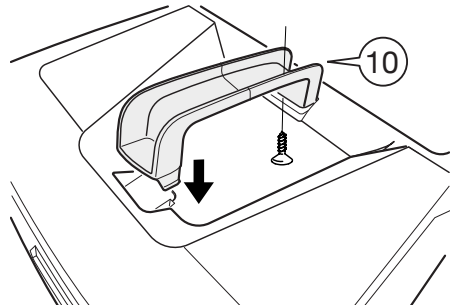

**NOTE** To attach to the **COLLECTION BASKET** to the lawnmower, lift the **REAR FLAP (12)** and hook into place on the mounting points at the rear of the lawnmower

## CUTTING HEIGHT ADJUSTMENT

---

When mowing high grass, start with the maximum cutting height and make a second cut with a lower cutting height.

Pull the **CUTTING HEIGHT ADJUSTMENT LEVER (13)** towards the rear wheel.

Moving the **CUTTING HEIGHT ADJUSTMENT LEVER (13)** towards the front will lower the ride height giving a closer cut.

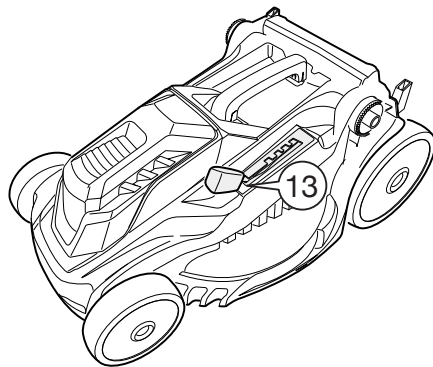
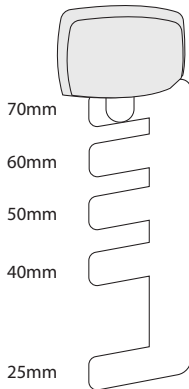

## GRASS INDICATOR

---

The **GRASS INDICATOR (14)** is equipped with a hatch that indicates the filling during operation.

When the hatch opens during operation, the grass collector has sufficient volume left to collect grass.

When the hatch closes, the grass collector is full and must be emptied.

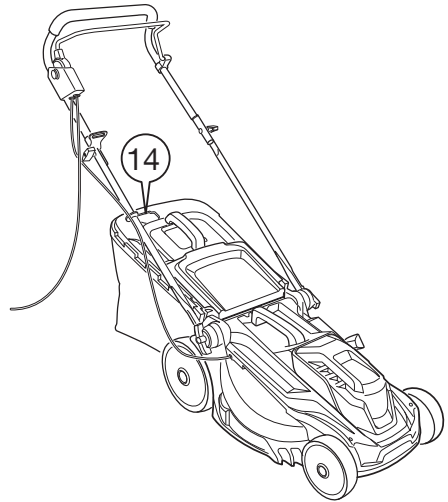
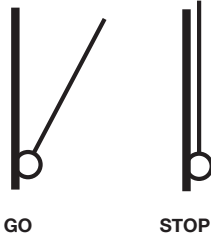

## OPERATION

---

Press and hold **SAFETY BUTTON (1)** then squeeze the **SWITCH LEVER (2)** towards the handle. Release the **SAFETY BUTTON (1)**.

To stop the lawnmower, release the **SWITCH LEVER (2)**

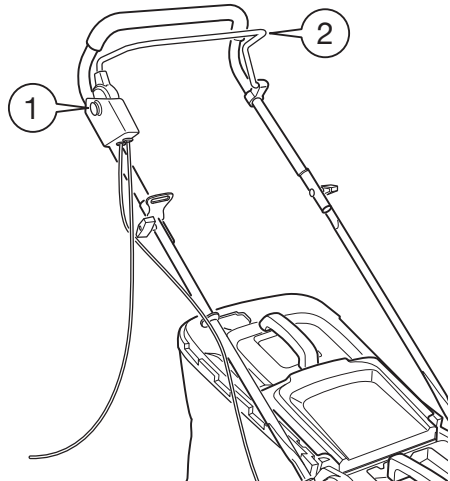

**IMPORTANT** To prevent the machine switching on accidentally, the lawnmower is equipped with a **SAFETY BUTTON (1)** which must be pressed before the **SWITCH LEVER (2)** can be activated.

The lawnmower switches itself off when the switch is released.

**Recommend to repeat this process several times with the blade removed so that you familiarise yourself with this functionality.**



## CUTTING BLADE MAINTENANCE & REMOVAL

---

**IMPORTANT** Disconnect the lawnmower from the mains and wait until the blade has stopped rotating before proceeding.

Use heavy-duty gloves or a cloth to grip the blade.

Replace this cutting blade after 50 hours mowing or 2 years whichever is sooner regardless of condition. If the cutting blade is cracked or damaged, you must immediately replace it with a new one.

Loosen the hex nut anti-clockwise using a suitable wrench (Size 16 mm) and remove it together with the cutting blade, the flat washer and the spring washer.

Replace the cutting blade with a new one of the same type.

Check the status of flange onto the spindle firstly, then attach the cutting blade, the flat washer, the spring washer and the hex nut in the correct order.

Tighten the hex nut clockwise with 45 Nm min, 50 Nm max. to ensure safe operation of your product.

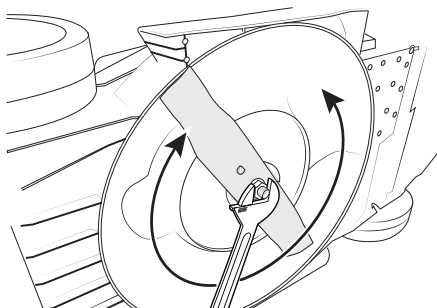

## CLEANING & MAINTENANCE

---

**IMPORTANT** Disconnect the lawnmower from the mains and wait until the blade has stopped rotating before proceeding.

Use heavy-duty gloves or a cloth to grip the blade.

### Blade maintenance

Regularly remove grass and dirt from the blade. At the beginning of the season, carefully examine the condition of the blade.

- If the blade is blunt, sharpen or replace the blade.
- If the blade is damaged or worn, fit a new blade.

Keep all air vents and the motor housing free of dirt and dust where possible.

Wipe the equipment with a clean cloth or clean with compressed air at low pressure.

We recommend that you clean the lawnmower immediately each time you have finished using it.

Clean the equipment regularly with a moist cloth and some soft soap. Do not use cleaning agents or solvents; Ensure to prevent water ingress into the motor.



**DISPOSAL INFORMATION** Please recycle where facilities exist. Check with your local authority for recycling advice.

**CUSTOMER SERVICE** If you are having difficulty using this product and require support, please contact [support@domu.co.uk](mailto:support@domu.co.uk)

**WARRANTY** To register your product and find out if you qualify for a free extended warranty please go to [www.vonhaus.com/warranty](http://www.vonhaus.com/warranty). Please retain a proof of purchase receipt or statement as proof of the purchase date. The warranty only applies if the product is used solely in the manner indicated in the warnings page of this manual, and all other instructions have been followed accurately. Any abuse of the product or the manner in which it is used will invalidate the warranty. Returned goods will not be accepted unless re-packaged in its original packaging and accompanied by a relevant and completed returns form. This does not affect your statutory rights. No rights are given under this warranty to a person acquiring the appliance second-hand or for commercial or communal use.

**COPYRIGHT** All material in this instruction manual are copyrighted by DOMU Brands. Any unauthorised use may violate worldwide copyright, trademark, and other laws.

## THANK YOU

Thank you for purchasing your product/appliance. Should you require further assistance with your purchase, you can contact us at [support@domu.co.uk](mailto:support@domu.co.uk)  
VonHaus is a registered trademark of DOMU Brands Ltd. Made in China for DOMU Brands. M24 2RW.